

2/2

VALVES FOR WATER AND NEUTRAL LIQUIDS

PILOT OPERATED

BRASS

PIPE MOUNTING

NORMALLY OPEN

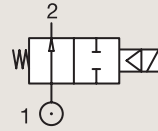

Port size	Orifice Ø	Flow factors			Operating Pressure Differential			Fluid Temp.		Seat Seal	Valve Ref.	Housing Ref.	Coil Ref.	Power		Coil Group	Dwg. No.
		Kv l/min	KV m³/h	Qn l/min	Min bar	Max(MOPD) AC bar	DC bar	Min °C	Max °C					AC W	DC W		
1/4"	12	32	1.92	2150	0.3	12	12	-10	100	FKM	322K4106	2995	481865	8	9	2.1	7094
	12	32	1.92	2150	0.3	12	12	-10	120	FKM	322K4106	4270	481000	8	8	2.1	7094
3/8"	12	45	2.7	3050	0.3	12	12	-10	100	FKM	322K4306	2995	481865	8	9	2.1	7094
	12	45	2.7	3050	0.3	12	12	-10	120	FKM	322K4306	4270	481000	8	8	2.1	7094
1/2"	12	50	3	3400	0.3	12	12	-10	100	FKM	322K4506	2995	481865	8	9	2.1	7094
	12	50	3	3400	0.3	12	12	-10	120	FKM	322K4506	4270	481000	8	8	2.1	7094
	15	60	3.6	3890	0.3	15	15	-10	100	NBR	322G75	2995	481865	8	9	2.1	3522
	15	60	3.6	3890	0.3	15	15	-10	100	NBR	322G75	4270	481000	8	8	2.1	3522
3/4"	18	100	6	9400	0.3	12	12	-10	100	FKM	322K4606	2995	481865	8	9	2.1	7099
	18	100	6	9400	0.3	12	12	-10	120	FKM	322K4606	4270	481000	8	8	2.1	7099
	20	135	8.1	9500	0.3	16	16	-10	100	NBR	322G36	2995	481865	8	9	2.1	3442
	20	135	8.1	9500	0.3	16	16	-10	100	NBR	322G36	4270	481000	8	8	2.1	3442

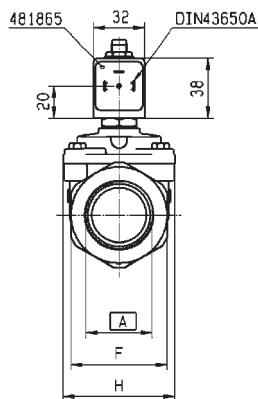
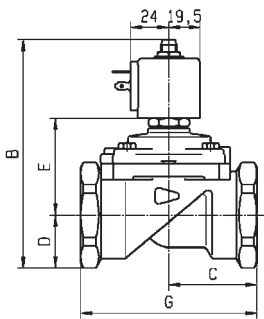

RA2CORP	A	B	C	D	E	F	G	H
321/322/E321G36	BSP 3/4"	121	50	23	54	41	100	70
321/322/E321G37	OSP 1"	151	50	23	54	41	100	70
321/322/E321G38	OSP 1 1/4"	137.5	35	33	60.5	60	110	70
321/322/E321G39	BSP 1 1/2"	144	75	33	62	60	140	99
321G2956/G2967	UNF 1 7/8"	144	75	33	67	60	140	99
U321A/322G40...	BSP 2"	158.5	80	41.5	73	75	150	99

Drawing 3442



For this page	Port size	Orifice (mm)	Kv (l/min)	MOPD (bar)	Fluid Temp (°C)
From	1/4"	12	32	12	-10
To	3/4"	20	135	16	120

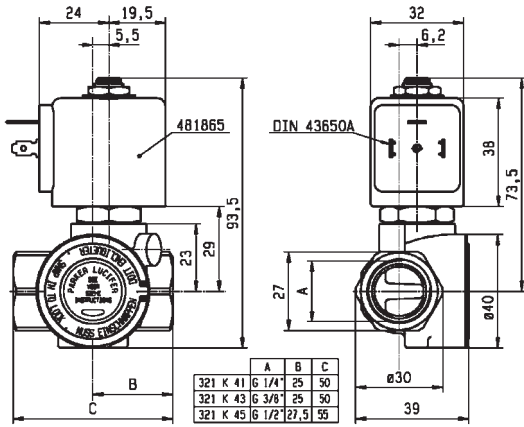

Drawing 7094

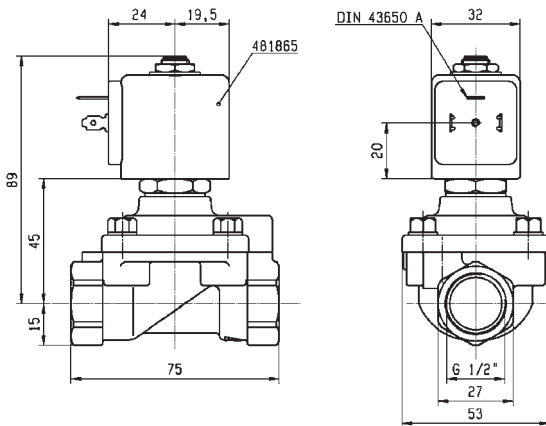

Drawing 3522

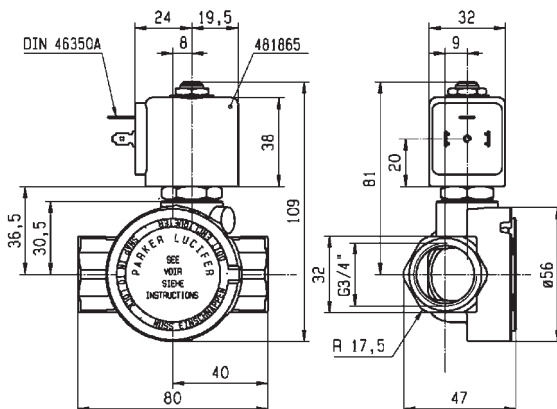

Drawing 7099